

# ASLAN II series

Fanless industrial panel mount panel PCs and built-in systems for control cabinets

## Features

- 15.6" ~ 21.5" panel mount panel PCs
- Intel® Celeron® J6412 CPU
- 1x DDR4 SO-DIMM 2133/2400/3200 up to 32GB
- Protection against overvoltage and reverse power supply
- IP66 front panel



## ASLAN II series: Powerful & fanless panel mount panel PCs for demanding industrial applications

With the introduction of the ASLAN II series, BRESSNER Technology is setting new standards in the field of industrial panel mount panel PCs. The ASLAN II series builds on the success of the well-known ASLAN series and now offers even more performance, robustness and flexibility for industrial and multimedia applications.

### Improved performance and versatility in a robust design

The ASLAN II series is available in 15.6", 18.5" and 21.5" display sizes and features powerful Intel® Elkhart Lake Celeron® J6412 processors. These processors offer significant performance and efficiency improvements over previous models, making them perfect for demanding industrial applications. The industrial 10-point project capacitive touch screen offers precise and responsive operation, making it ideal for complex and interactive applications.

The ASLAN II panel PCs feature an aluminum alloy that not only provides a lightweight yet sturdy housing, but also ensures excellent heat dissipation. The front panel offers IP66 protection, making it resistant to dust and strong water jets – ideal for harsh industrial environments.

### Maximum flexibility and expandability

The ASLAN II series supports both standard VESA and panel mount mounting options for maximum installation flexibility. With support for 2.5 inch HDD/SSD expansions and Mini PCIe/M.2 module expansions, the systems can be customized to meet specific requirements. With dual 2.5GbE LAN ports, the ASLAN II series offers a fast and reliable network connection that meets the requirements of modern industrial applications.

## Appearance



ASLAN II 15.6" & 21.5"



ASLAN II 18.5"

# ASLAN II series

Fanless industrial panel mount panel PCs and built-in systems for control cabinets

	15.6"	18.5"	21.5"
<b>SYSTEM</b>			
CPU	Intel® Elkhart Lake SoC CPU J6412, QC, 2.60-2.0GHz, 10W		
Graphics	Intel® UHD graphics for Intel® 10th Gen. processors		
RAM	1x DDR4 SO-DIMM 2133/2400/3200MHz socket, (up to 32GB), 4GB DDR4 SO-DIMM pre-installed[1] (CTOS)		
Storage	1 x M.2 2242 SSD, 128GB M.2 SSD pre-installed[1] (CTOS)		
Watchdog	Programmable 255 levels timer interval, from 1~255 sec/min		
Expansions	1x Mini PCIe slot (PCIe/USB2.0 signal supported) 1x M.2 2230 slot (PCIe/USB2.0 signal supported) 1x M.2 2242 slot (SATA signal supported) 1x SIM socket for 3G/4G 1x 8bit GPIO 3.3V (jumper)/5V(standard) power supply 1x RS-232 – COM4 2x RS-232(RX/TX) – COM5/6 2x USB 2.0 – For touch 1x SATA3.0/Power supply 5V for HDD		
Operating System	Windows 10, Linux		
<b>DISPLAY</b>			
Display Size	15.6" (39.6cm) TFT LCD Panel	18.5" (47cm) TFT LCD Panel	21.5" (54.6cm) TFT LCD Panel
Resolution	1,920 x 1,080	1,366 x 768	1,920 x 1,080
Touchscreen	PCAP Multitouch	PCAP Multitouch	PCAP Multitouch
Brightness	450 nits	500 nits	250 nits
Aspect Ratio	16:9	16:9	16:9
Contrast	800:1	1000:1	1000:1
Viewing Angle	CR ≥ 10; 0x 187(H)/ 0y 187° (V)	89/89/89/89 (Typ.)(CR≥10)	CR > 10, 89° (H)/89° (V)
<b>INTERFACE</b>			
Ethernet	2x RJ-45, Intel® I226-V 2.5GbE		
USB	2x USB 3.1, 2x USB 2.0		
COM	1x RS-232/422/485 – COM1 1x RS-232(Standard)/RS-485(Jumper) – COM2 1x RS-232 – COM3		
Video	1x HDMI, up to 4,096 x 2,160 @ 60Hz		
Audio	Audio (Line-out & Mic-in 2 in 1), Realtek® ALC888S HD audio codec, 2x 4Ω3W speakers		
Power	1x power connection (2P Phoenix)		
Other	1x Remote ON-OFF		
<b>ENVIRONMENTAL</b>			
Chassis	Panel mount, Aluminum front panel and heat sink, SECC rear panel		
Cooling	Fanless		
Power Adapter	DC 12~36V		
Operating Temperature	-10°C ~ 60°C	-10°C ~ 60°C	-10°C ~ 50°C
Storage Temperature	-40°C ~ 70°C		
Vibration / Shock Resistance	Vibration: Random vibration 5~500Hz, 2Grms in operation, Sinusoidal vibration 5~500Hz, 2G non-operation Shock: 10g 11ms in operation, 30g 11ms non-operation		
Humidity	5% ~ 95% non-condensing		
Dimensions	395 x 66 x 245.5mm	470.8 x 73 x 317.4mm	528.2 x 66x 321.9mm
Weight	4.2kg	6.8kg	6.9kg
Mounting	Panel mounting, wall mounting, VESA mounting (75 x 75mm)		
IP Rating	Front IP66		
Certifications	CE, FCC		

[1] CTOS means Configure-to-Order-Service

# ASLAN II series

Fanless industrial panel mount panel PCs and built-in systems for control cabinets

## Technical drawing (mm) - 15.6"

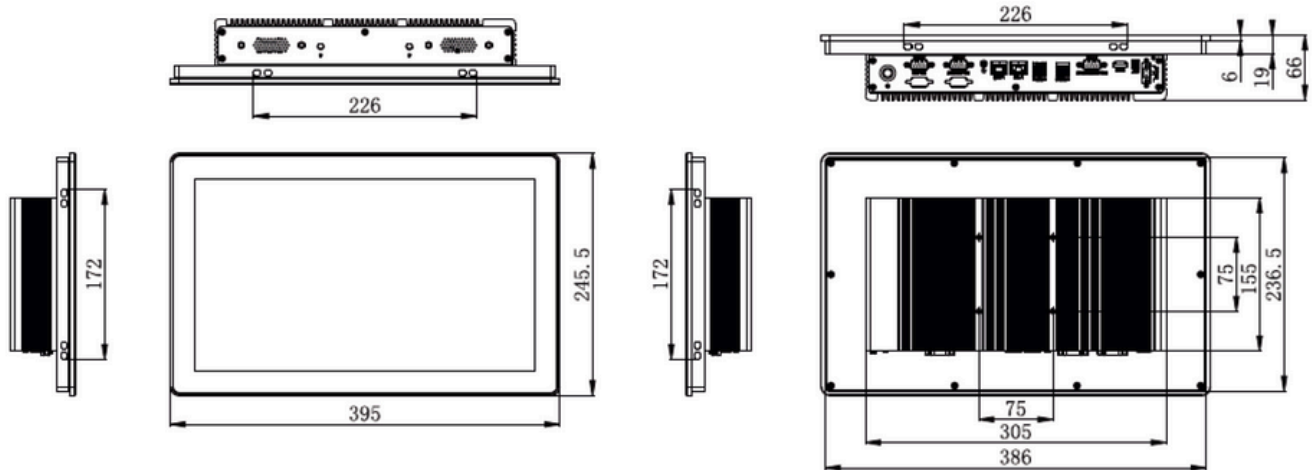

## Technical drawing (mm) - 18.5"

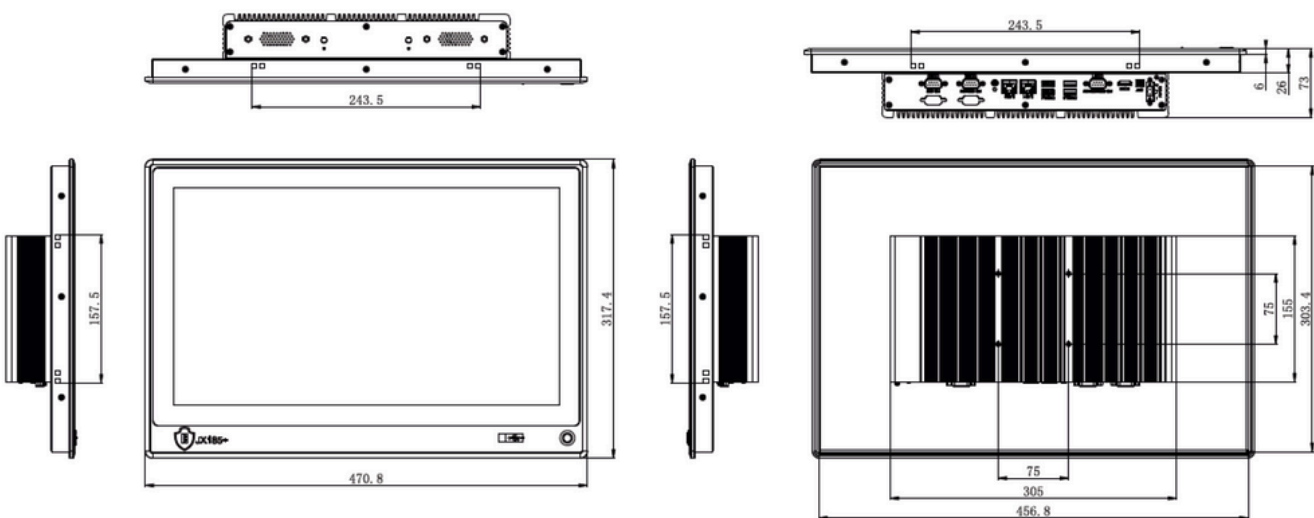

## Technical drawing (mm) - 21.5"

