

ASLAN II Core™ i5 series

Fanless industrial panel mount panel PCs and built-in systems for control cabinets

BRESSNER
A ONE STOP SYSTEMS COMPANY

Features

- 15.6" and 21.5" panel mount panel PCs
- Intel® Core™ 11th Gen. Tigerlake U i5/i3
- 1x DDR4 SO-DIMM 3200 MHz up to 32GB
- Protection against overvoltage and reverse power supply
- IP66 front panel



ASLAN II Core™ i5: Powerful & fanless panel mount panel PCs

With the introduction of the ASLAN II series, BRESSNER Technology is setting new standards in the field of industrial panel mount panel PCs. The ASLAN II series builds on the success of the well-known ASLAN series and now offers even more performance, robustness and flexibility for industrial and multimedia applications.

Improved performance and versatility in a robust design

The ASLAN II Core™ i5 series is available in 15.6" and 21.5" display sizes and features powerful Intel® Core™ 11th Gen. Tigerlake U i5/i3 processors. These processors offer significant performance and efficiency improvements, making them perfect for demanding industrial applications. The industrial 10-point project capacitive touch screen offers precise and responsive operation, making it ideal for complex and interactive applications.

The ASLAN II Core™ i5 panel PCs feature an aluminum alloy that not only provides a lightweight yet sturdy housing, but also ensures excellent heat dissipation. The front panel offers IP66 protection, making it resistant to dust and strong water jets – ideal for harsh industrial environments.

Maximum flexibility and expandability

The ASLAN II Core™ i5 series supports both standard VESA and panel mount mounting options for maximum installation flexibility. With support for 2.5 inch HDD/SSD expansions and Mini PCIe/M.2 module expansions, the systems can be customized to meet specific requirements. With 3x 2.5GbE LAN ports, the ASLAN II Core™ i5 series offers a fast and reliable network connection that meets the requirements of modern industrial applications.

Appearance



ASLAN II Core™ i5 series

Fanless industrial panel mount panel PCs and built-in systems for control cabinets

BRESSNER
A ONE STOP SYSTEMS COMPANY

	15.6"	21.5"
SYSTEM		
CPU	Onboard Intel® 11th Gen Core™ i3-1115G4 3.0G (2 Cores, 6M Cache, up to 4.1GHz) i5-1135G7 2.4G (4 Cores, 8M Cache, up to 4.2GHz)	
Graphics	Intel® UHD Graphics for 11th Gen, Intel® Processors & Intel® Iris® Xe Graphics	
RAM	1x DDR4 3200 MHz SO-DIMM, up to 32 GB	
Storage	1x M.2 2242 SSD	
Watchdog	Programmable 255 levels timer interval, from 1~255 sec/min	
Expansions	1x Mini-PCIe (PCIe/USB2.0 signal supported) 1x M.2 Key-E 2230 slot (WiFi +BT supported) 1x SIM socket 1x 8-Bit GPIO	
Operating System	Windows 10, Linux	
DISPLAY		
Display Size	15.6" (39.6cm) TFT LCD Panel	21.5" (54.6cm) TFT LCD Panel
Resolution	1,920 x 1,080	1,920 x 1,080
Touchscreen	PCAP Multitouch	PCAP Multitouch
Brightness	450 nits	250 nits
Aspect Ratio	16:9	16:9
Contrast	800:1	1000:1
Viewing Angle	CR ≥ 10, 89° (T)/89° (B)/89° (L)/89° (R)	CR ≥ 10, 89° (T)/89° (B) 89° (L)/89° (R)
INTERFACE		
Ethernet	3x RJ-45: 1x Intel® I226-V 2.5GbE 2x Intel® I210-AT GbE	
USB	4x USB 3.1	
COM	2x RS-232/422/485 (COM1/2) with DB-9 2x RS-232/RS-485, 2x RS-232 with 12PIN Phoenix connector	
Video	1x HDMI, up to 4,096 x 2,304 @ 60Hz	
Audio	Audio (Line-out & Mic-in 2 in 1), Realtek® ALC888S HD audio codec, 2x 4Ω3W speakers	
Power	1x power connection (2P Phoenix)	
Other	1x Remote ON-OFF	
ENVIRONMENTAL		
Chassis	Panel mount, Aluminum front panel and heat sink, SECC rear panel	
Cooling	Fanless	
Power Adapter	DC 10~36V	
Operating Temperature	-10°C ~ 50°C	
Storage Temperature	-40°C ~ 70°C	
Vibration / Shock Resistance	Vibration: Random vibration 5~500Hz, 2Grms in operation, Sinusoidal vibration 5~500Hz, 2G non-operation Shock: 10g 11ms in operation, 30g 11ms non-operation	
Humidity	5% ~ 95% non-condensing	
Dimensions	395 (W) x 59 (D) x 245.5 (H) mm	528.2 (W) x 59 (D) x 321.9 (H) mm
Weight	4.54 kg	7.14 kg
Mounting	Panel mounting, wall mounting, VESA mounting (100 x 100mm)	
IP Rating	Front IP66	
Certifications	CE, FCC	

ASLAN II Core™ i5 series

Fanless industrial panel mount panel PCs and built-in systems for control cabinets

Technical drawing (mm) - 15.6"

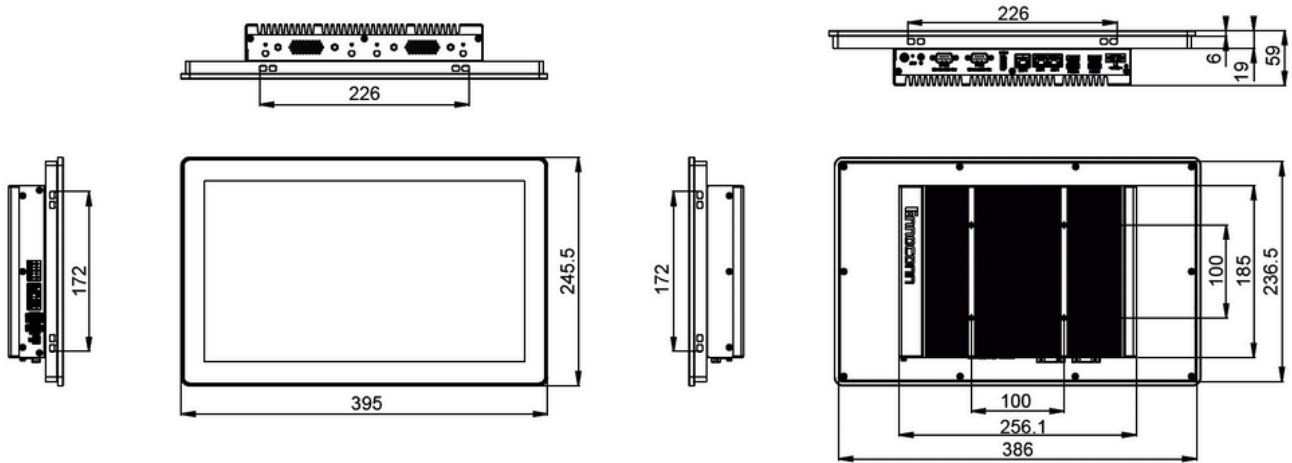

Technical drawing (mm) - 21.5"

